



3A LDO VOLTAGE REGULATOR

DESCRIPTION

The AMS1085 is a positive low voltage dropout regulator, voltage dropout is only 1.18V at 3A.

AMS1085 has two versions: the fixed version and the adjustable version. VOUT has a tolerance of less than 1% for fixed versions 1.5V, 1.8V, 2.5V, 3.3V, 5.0V and adjustable version.

The AMS1085 integrates overheating protection and current limit circuits. It is an suitable for all electronic products.

FEATURES

- * 1% accuracy for fixed output VOUT while the voltage is 1.5V, 1.8V, 2.5V, 3.3V, 5.0V and the adjustable output VOUT
- * Low Dropout Voltage: 1.18V at 3A output current
- * Current Limiting: 4.5A
- * Load regulation : 0.1% typical (adjustable version)
- * Line regulation : 0.015% typical (adjustable version)
- * Temperature Range: 0°C to 125°C

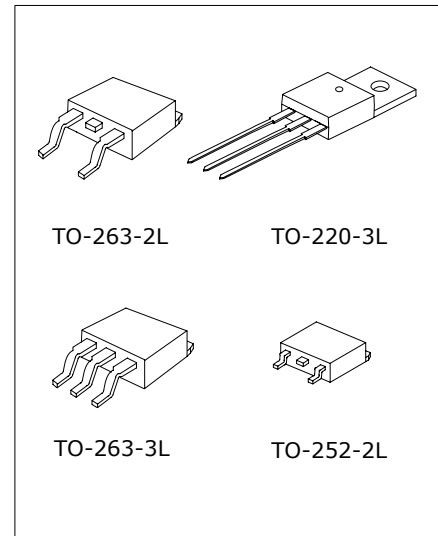

APPLICATIONS

- * High Efficiency Linear Regulators
- * SMPS Post-Regulator
- * Battery Charger
- * Microprocessor Supply
- * Desktop PCs, RISC and embedded processors'supply

ORDERING INFORMATION (Temperature range: 0°C ~125°C)

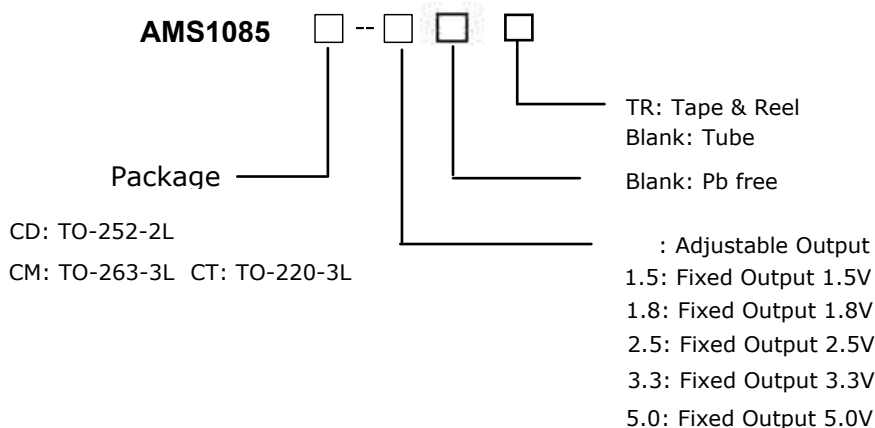



PART NO	Package	Marking	Material	Packing Type
AMS1085D-ADJ	TO-252-2L	AMS1085CD	Pb free	Tube
AMS1085D-ADJTR		AMS1085CD	Pb free	Tape & Reel
AMS1085D-1.5		AMS1085CD-1.5	Pb free	Tube
AMS1085D-1.5TR		AMS1085CD-1.5	Pb free	Tape & Reel
AMS1085D-1.8		AMS1085CD-1.8	Pb free	Tube
AMS1085D-1.8TR		AMS1085CD-1.8	Pb free	Tape & Reel
AMS1085D-2.5		AMS1085CD-2.5	Pb free	Tube
AMS1085D-2.5TR		AMS1085CD-2.5	Pb free	Tape & Reel
AMS1085D-3.3		AMS1085CD-3.3	Pb free	Tube
AMS1085D-3.3TR		AMS1085CD-3.3	Pb free	Tape & Reel
AMS1085D-5.0		AMS1085CD-5.0	Pb free	Tube
AMS1085D-5.0TR		AMS1085CD-5.0	Pb free	Tape & Reel
AMS1085S-ADJ		TO-263-3L	AMS1085CM	Pb free
AMS1085S-ADJTR	AMS1085CM		Pb free	Tape & Reel
AMS1085S-1.5	AMS1085CM-1.5		Pb free	Tube
AMS1085S-1.5TR	AMS1085CM-1.5		Pb free	Tape & Reel
AMS1085S-1.8	AMS1085CM-1.8		Pb free	Tube
AMS1085S-1.8TR	AMS1085CM-1.8		Pb free	Tape & Reel
AMS1085S-2.5	AMS1085CM-2.5		Pb free	Tube
AMS1085S-2.5TR	AMS1085CM-2.5		Pb free	Tape & Reel
AMS1085S-3.3	AMS1085CM-3.3		Pb free	Tube
AMS1085S-3.3TR	AMS1085CMS-3.3		Pb free	Tape & Reel
AMS1085S-5.0	AMS1085CM-5.0		Pb free	Tube
AMS1085S-5.0TR	AMS1085CM-5.0		Pb free	Tape & Reel
AMS1085T-ADJ	TO-220-3L		AMS1085CT	Pb free
AMS1085T-1.5		AMS1085CT-1.5	Pb free	Tube
AMS1085T-1.8		AMS1085CT-1.8	Pb free	Tube
AMS1085T-2.5		AMS1085CT-2.5	Pb free	Tube
AMS1085T-3.3		AMS1085CT-3.3	Pb free	Tube
AMS1085T-5.0		AMS1085CT-5.0	Pb free	Tube
AMS1085S2-ADJ	TO-263-2L	AMS1085CM	Pb free	Tube
AMS1085S2-ADJTR		AMS1085CM	Pb free	Tape & Reel
AMS1085S2-1.5		AMS1085CM-1.5	Pb free	Tube
AMS1085S2-1.5TR		AMS1085CM-1.5	Pb free	Tape & Reel
AMS1085S2-1.8		AMS1085CM-1.8	Pb free	Tube
AMS1085S2-1.8TR		AMS1085CM-1.8	Pb free	Tape & Reel
AMS1085S2-2.5		AMS1085CM-2.5	Pb free	Tube



PART NO	Package	Marking	Material	Packing Type
AMS1085S2-2.5TR	TO-263-2L	AMS1085CM-2.5	Pb free	Tape & Reel
AMS1085S2-3.3		AMS1085CM-3.3	Pb free	Tube
AMS1085S2-3.3TR		AMS1085CM-3.3	Pb free	Tape & Reel
AMS1085S2-5.0		AMS1085CM-5.0	Pb free	Tube
AMS1085S2-5.0TR		AMS1085CM-5.0	Pb free	Tape & Reel

BLOCK DIAGRAM

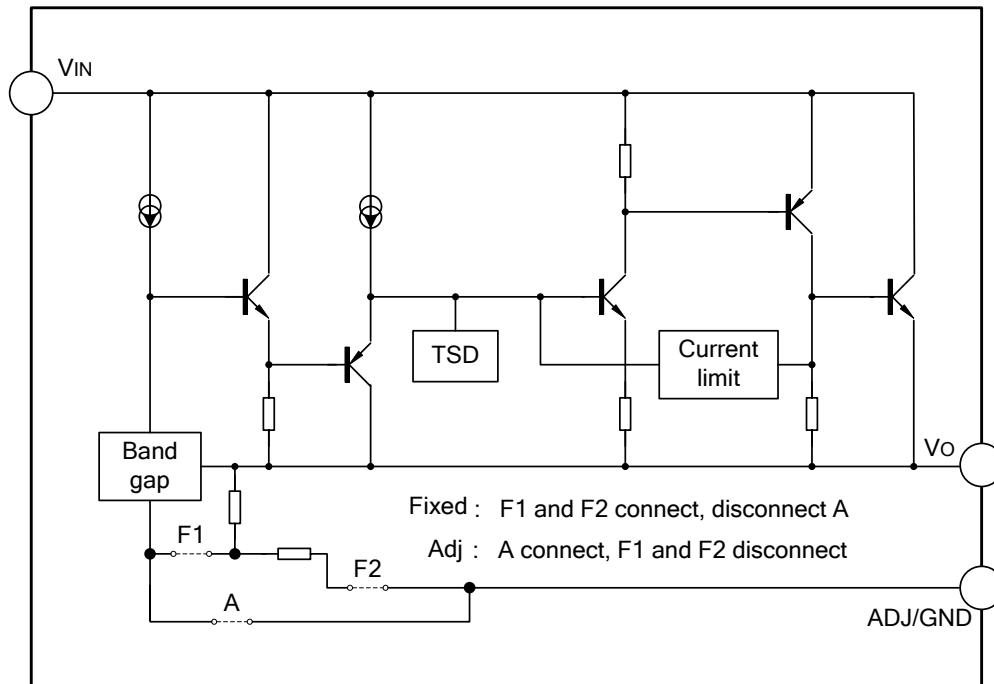

ABSOLUTE MAXIMUM

Characteristics	Symbol	Ratings	Unit
Input Supply Voltage	V _{IN}	20	V
Lead Temperature (Soldering, 5 Seconds)	T _{LEAD}	260	°C
Operating Junction Temperature Range	T _J	150	°C
Storage Temperature	T _S	-65 ~ +150	V
Power Dissipation	PD	Internally Limited (Note1)	mW
ESD Tolerance (Minimum)	ESD	2000	V

Note1: The maximum allowable power dissipation is a function of maximum operating junction temperature T_J (max), the junction to ambient thermal resistance θ_{JA}, and the ambient temperature T_{amb}. The maximum allowable power dissipation at any ambient temperature is given: PD (max) = (T_J (max) - T_{amb})/θ_{JA}, exceeding the maximum allowable power limit will result in excessive die temperature; thus, the regulator will go into thermal shutdown. The junction to ambient thermal resistance θ_{JA} of different packages may be different, and the value of θ_{JA} depends on mounting technique.



RECOMMENDED OPERATING CONDITIONS

Characteristics	Symbol	Ratings	Unit
Input Supply Voltage	V _{IN}	12	V
Operating Junction Temperature Range	T _J	0 ~ +125	°C

ELECTRICAL CHARACTERISTICS (T_{amb}=25°C, unless otherwise specified. Limits appearing in Boldface type apply over the entire junction temperature range for operation, 0°C to 125°C.)

Characteristics	Symbol	Conditions	Min.	Typ.	Max.	Unit
Reference Voltage	V _{REF}	AMS1085-ADJ, I _{OUT} =10mA, V _{IN} -V _{OUT} =3V, 10mA ≤ I _{OUT} ≤ 3A, 1.5V ≤ V _{IN} -V _{OUT} ≤ 5V	1.238	1.250	1.262	V
			1.225	1.250	1.270	
Output Voltage	V _{OUT}	AMS1085-1.5, I _{OUT} =10mA, V _{IN} =4.5V, 10mA ≤ I _{OUT} ≤ 3A, 3.0V ≤ V _{IN} ≤ 6V	1.485	1.5	1.515	V
			1.47	1.5	1.53	
		AMS1085-1.8, I _{OUT} =10mA, V _{IN} =4.8V, 10mA ≤ I _{OUT} ≤ 3A, 3.3V ≤ V _{IN} ≤ 6V	1.782	1.8	1.818	V
			1.764	1.8	1.836	
		AMS1085-2.5, I _{OUT} =10mA, V _{IN} =5.5V 10mA ≤ I _{OUT} ≤ 3A, 4.0V ≤ V _{IN} ≤ 7V	2.475	2.5	2.525	V
			2.45	2.5	2.55	
AMS1085-3.3, I _{OUT} =10mA, V _{IN} =6.3V, 10mA ≤ I _{OUT} ≤ 3A, 4.8V ≤ V _{IN} ≤ 8V	3.267	3.3	3.333	V		
	3.234	3.3	3.366			
Line Regulation	ΔV _{OUT}	AMS1085-ADJ, I _{OUT} =10mA, 2.85V ≤ V _{IN} ≤ 10V		0.015	0.2	%
				0.035	0.2	
		AMS1085-1.5, I _{OUT} =10mA, 3.0V ≤ V _{IN} ≤ 10V		0.5	6	mV
				1	6	
		AMS1085-1.8, I _{OUT} =10mA, 3.3V ≤ V _{IN} ≤ 10V		0.5	6	mV
				1	6	
AMS1085-2.5, I _{OUT} =10mA, 4.0V ≤ V _{IN} ≤ 10V		0.5	6	mV		
		1	6			
AMS1085-3.3, I _{OUT} =10mA, 4.8V ≤ V _{IN} ≤ 10V		0.5	6	mV		
		1	6			
AMS1085-5.0, I _{OUT} =10mA, 6.5V ≤ V _{IN} ≤ 10V		0.5	10	mV		
		1	10			



Characteristics	Symbol	Conditions	Min.	Typ.	Max.	Unit
Load Regulation	ΔV_{OUT}	AMS1085-ADJ, $0mA \leq I_{OUT} \leq 3A$, $V_{IN} - V_{OUT} = 3V$		0.1 0.2	0.3 0.4	%
		AMS1085-1.5, $0mA \leq I_{OUT} \leq 3A$, $V_{IN} - V_{OUT} = 3V$		3 7	15 20	mV
		AMS1085-1.8, $0mA \leq I_{OUT} \leq 3A$, $V_{IN} - V_{OUT} = 3V$		3 7	15 20	mV
		AMS1085-2.5, $0mA \leq I_{OUT} \leq 3A$, $V_{IN} - V_{OUT} = 3V$		3 7	15 20	mV
		AMS1085-3.3, $0mA \leq I_{OUT} \leq 3A$, $V_{IN} - V_{OUT} = 3V$		3 7	15 20	mV
		AMS1085-5.0, $0mA \leq I_{OUT} \leq 3A$, $V_{IN} - V_{OUT} = 3V$		5 10	20 35	mV
Dropout Voltage	V_{DROP}	$I_{OUT} = 3A$, ΔV_{REF} , $\Delta V_{OUT} = 1\%$		1.18	1.3	V
Current Limiting	I_{LIMIT}	$V_{IN} - V_{OUT} = 3V$		4.5		A
Minimum Load Current	I_{LOAD} (MIN)	$V_{IN} = 10V$ (AMS1085-ADJ)		3	10	mA
Quiescent Current	I_Q	$V_{IN} = 10V$ (AMS1085)		5	10	mA
Ripple Rejection	PSRR	$f_{RIPPLE} = 120Hz$, $C_{OUT} = 25\mu F$ $I_{OUT} = 3A$, $V_{IN} - V_{OUT} = 3V$	60	72		dB
Adjust Pin Current	I_{ADJ}	$V_{IN} = 4.25V$, $I_{OUT} = 10mA$		55	120	μA
Adjust Pin Current Change	ΔI_{ADJ}	$10mA \leq I_{OUT} \leq 3A$, $1.5V \leq (V_{IN} - V_{OUT}) \leq 4.5V$		0.2	5	μA
Temperature Stability		$I_{OUT} = 10mA$, $V_{IN} - V_{OUT} = 1.5V$		0.5		%
Long Term Stability		$T_{amb} = 125^\circ C$, 1000Hrs		0.5		%
RMS Output Noise(% of Vout)		$10Hz \leq f \leq 10kHz$		0.003		%
Thermal Resistance	θ_{JA}	TO-263-3L		60		$^\circ C/W$
		TO-263-2L		60		
		TO-220-3L		60		
		TO-252-2L		100		

PIN CONFIGURATION

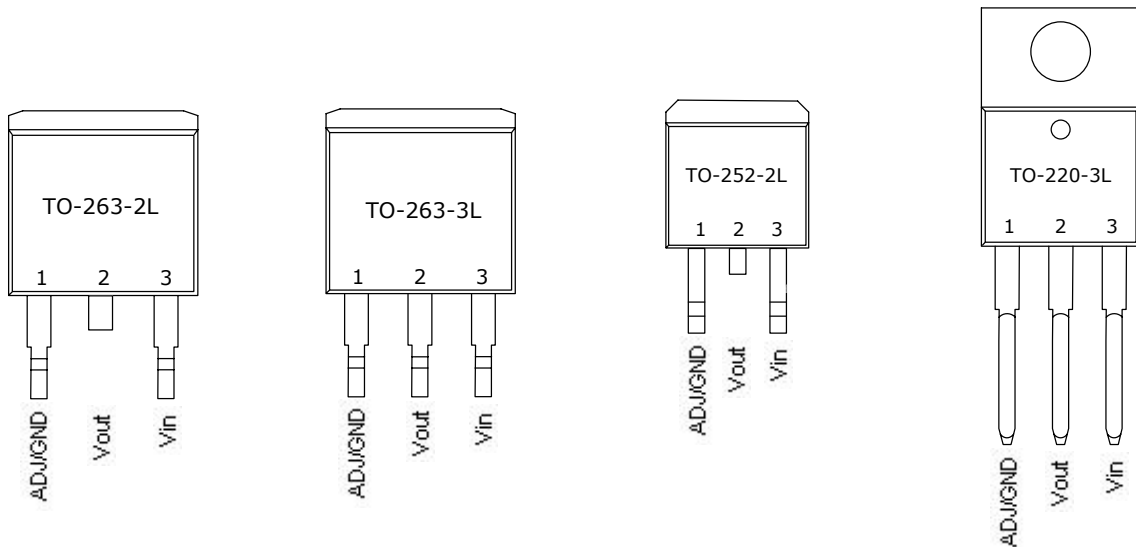

PIN DESCRIPTION

Pin No.	Pin name	I/O	Functions
1	GND/ADJ	--/O	Ground/ADJ
2	VOUT	O	Output voltage
3	VIN	I	Input supply voltage

FUNCTION DESCRIPTION

The AMS1085 is a LDO regulator, its pass transistor is made up of a single NPN transistor being driven by a PNP. The dropout voltage is defined as: $V_{DROP} = V_{BE} + V_{SAT}$.

The AMS1085 has two versions: the fixed output version and the adjustable output version. Output voltages can be 1.5V, 1.8V, 2.5V, 3.3V, and 5.0V. On-chip thermal shut-down circuit provides protection against overload and overheating that would create excessive junction temperature.

The adjustable output version requires a 22 μ F or bigger tantalum capacitor at output for AMS1085 stability. The capacitor for fixed output version can be smaller and should be determined base on actual application. Generally, the stability of linear regulator stability decreases with output currents increase.

TYPICAL APPLICATION CIRCUIT

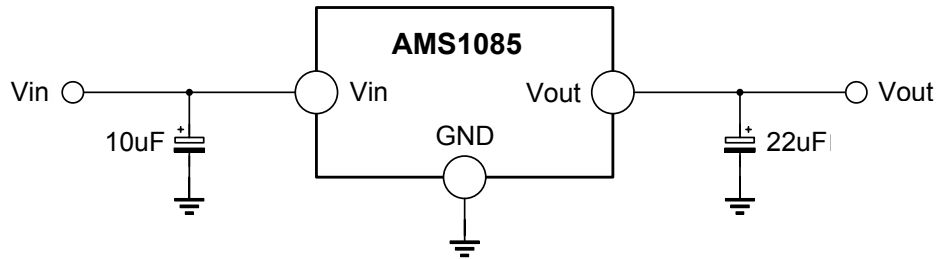

Figure 1. Typical Fixed Output Voltage

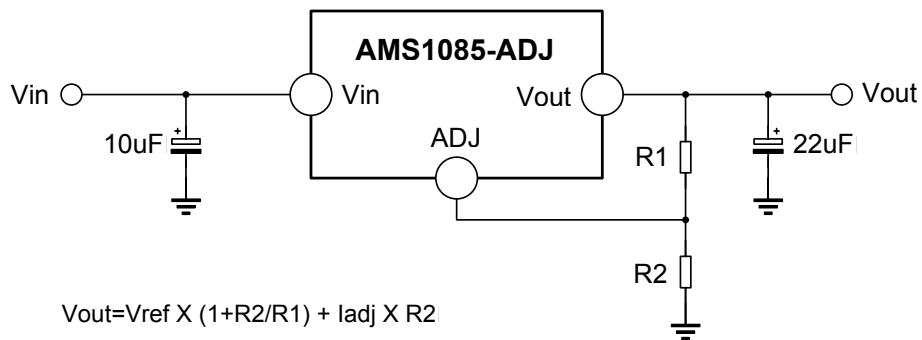

Figure 2. Typical Adjustable Output Voltage

Note: The above circuit and parameters are reference only, please set the parameters of the real application circuit based on the real test.



TYPICAL CHARACTERISTICS CURVES

Output Voltage Change vs. Temperature Stability

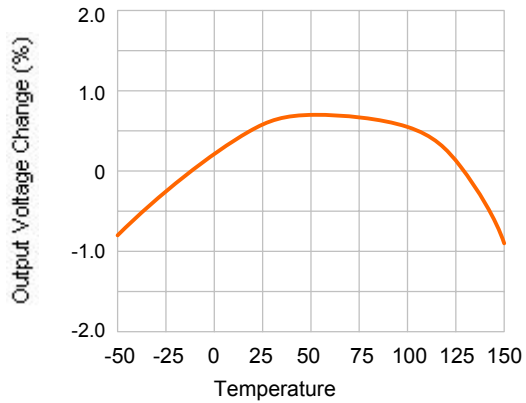

PSRR vs. Frequency

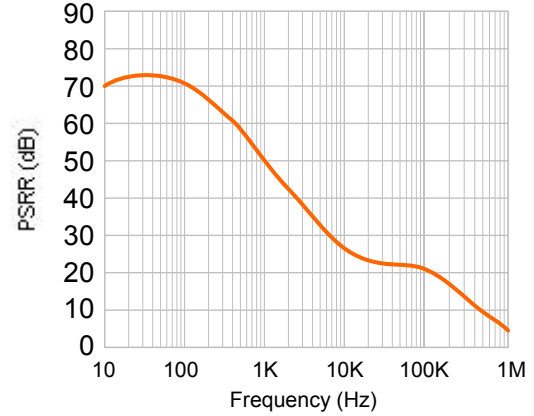

Short-Circuit Current vs. Dropout Voltage

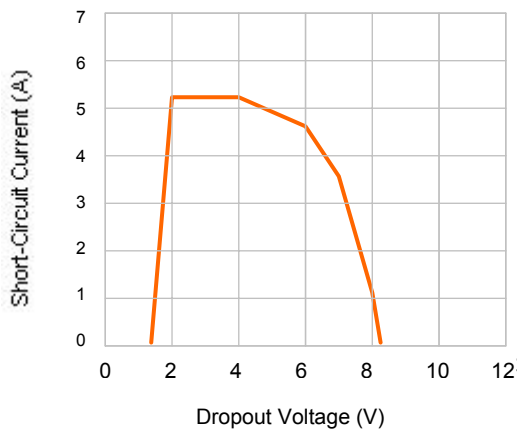

Load Transient Response

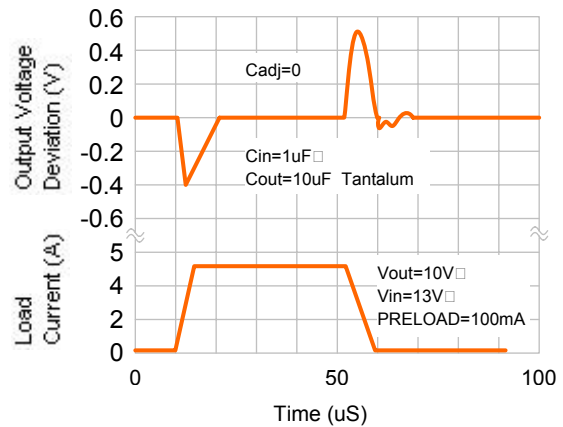

Line Transient Response

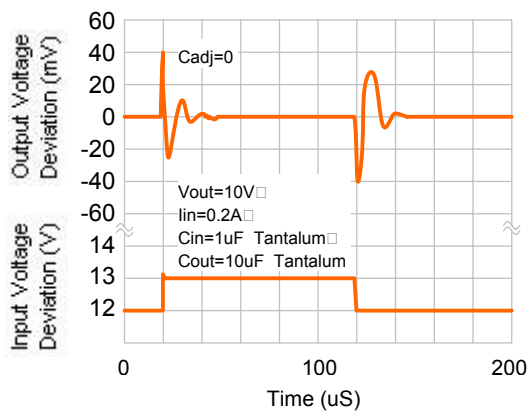

Adjust Pin Current vs. Temperature

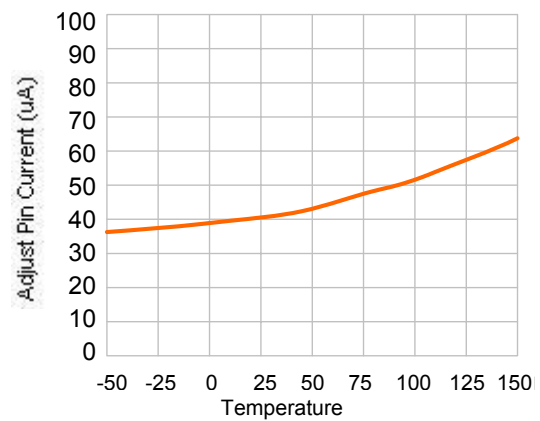



PACKAGE OUTLINE

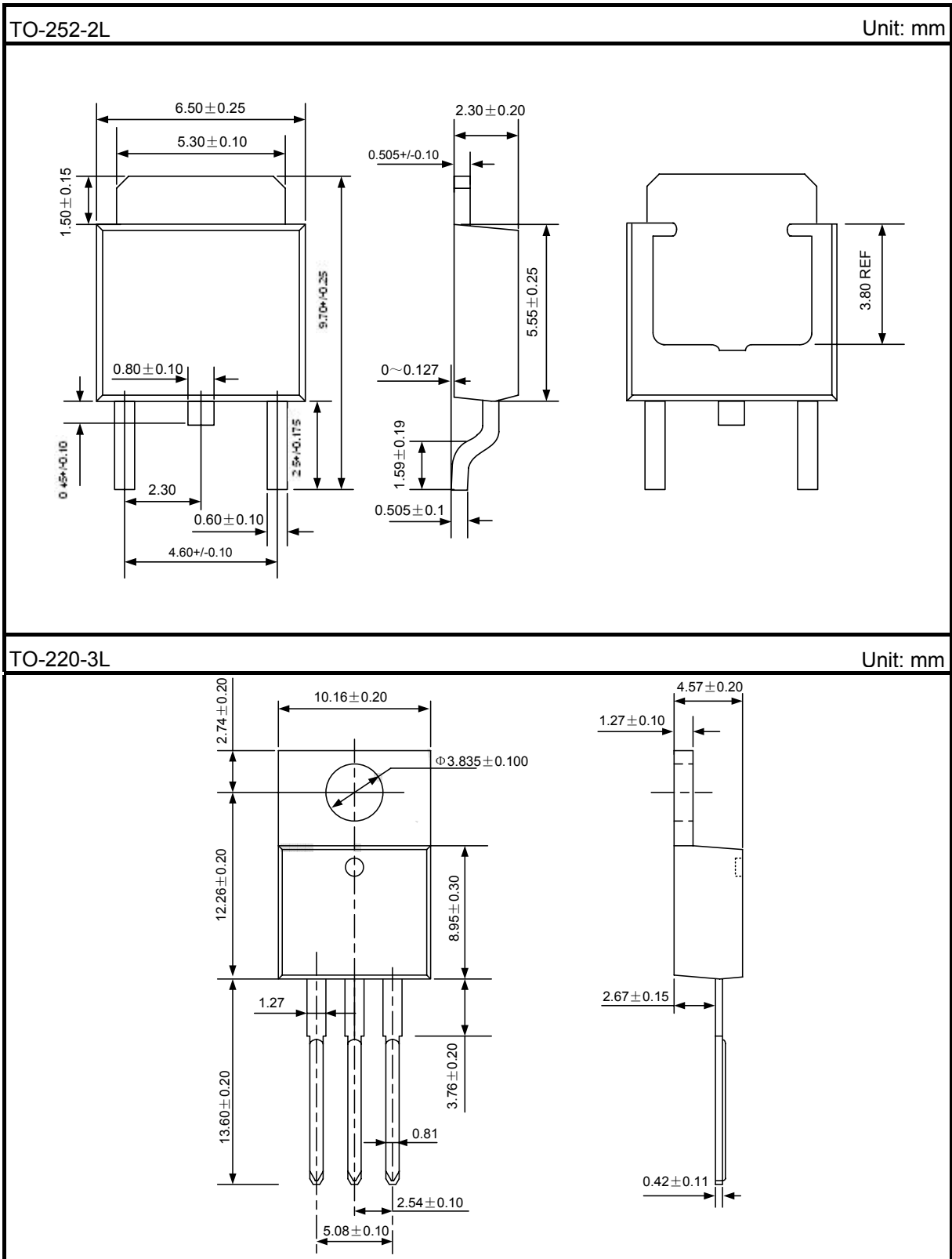



PACKAGE OUTLINE

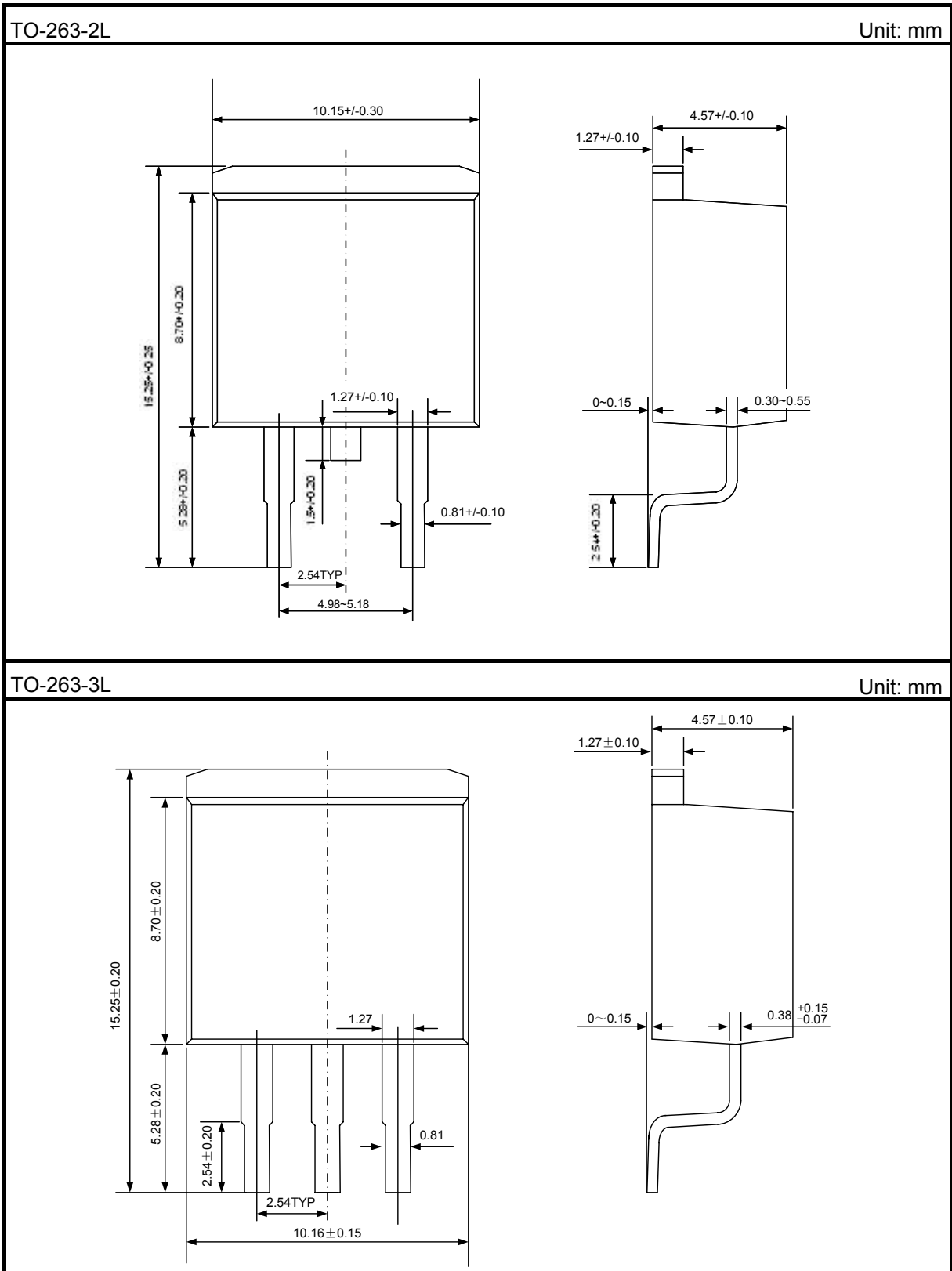



Disclaimer:

- AMS reserves the right to make changes to the information herein for the improvement of the design and performance without further notice! Customers should obtain the latest relevant information before placing orders and should verify that such information is complete and current.
- All semiconductor products malfunction or fail with some probability under special conditions. When using AMS products in system design or complete machine manufacturing, it is the responsibility of the buyer to comply with the safety standards strictly and take essential measures to avoid situations in which a malfunction or failure of such AMS products could cause loss of body injury or damage to property.
- AMS will supply the best possible product for customers!